



life.augmented

ST IO-Link Products Introduction

Pony WANG

Strategic Marketing / Automation Competence Center

pony.wang@st.com

Jun 23, 2020

IO-Link application

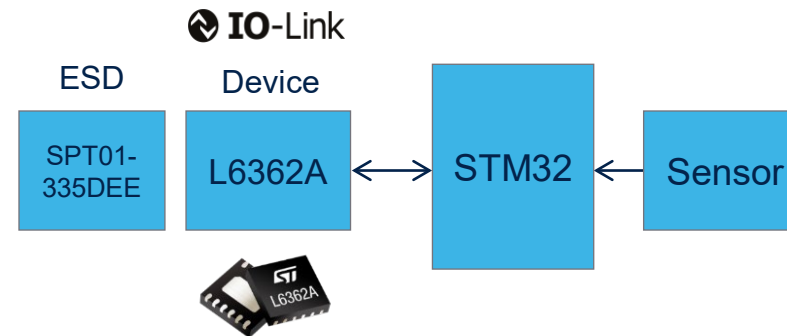
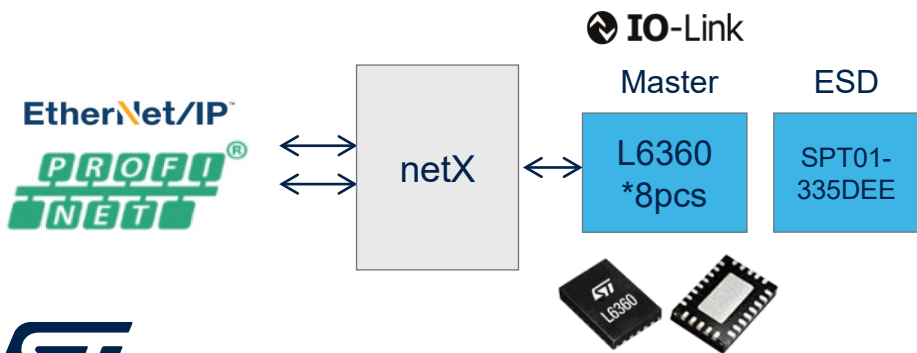
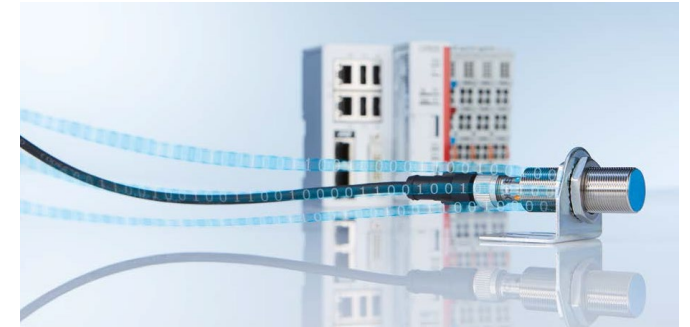
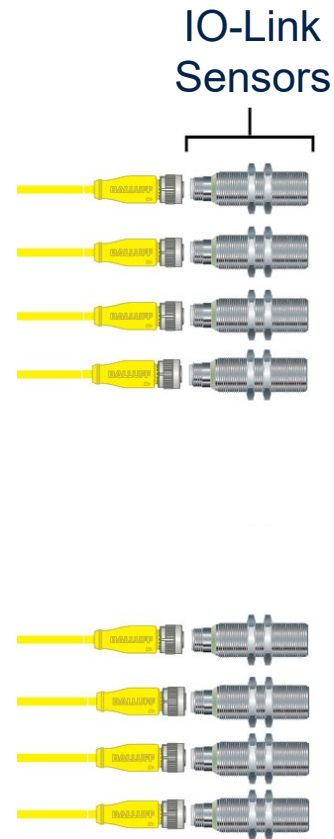
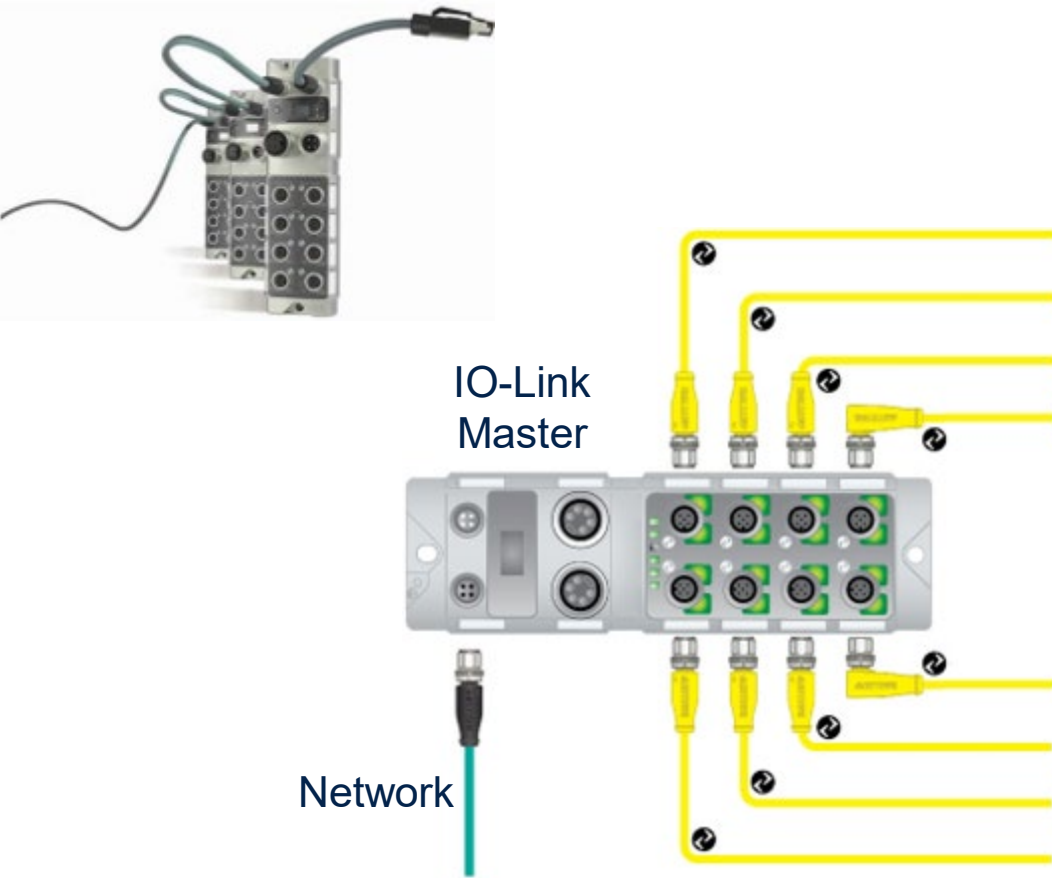

IO-Link Device PHY

IO-Link device PHY

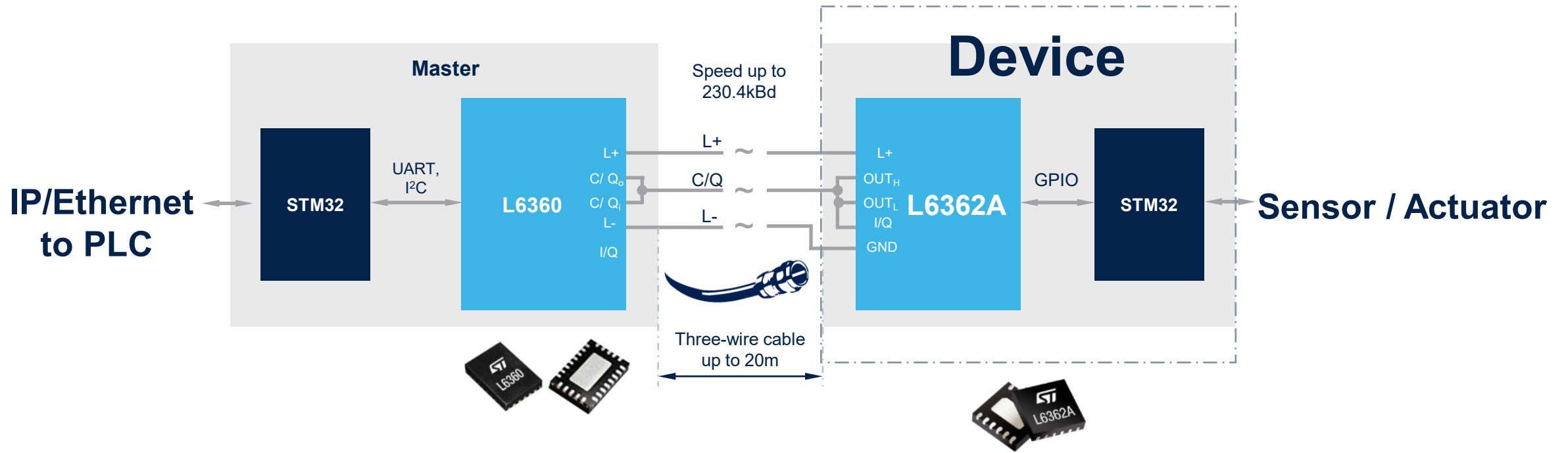

- Easy Installation
- Easy Configuration
- Diagnostic Function

L6362A IO-Link device

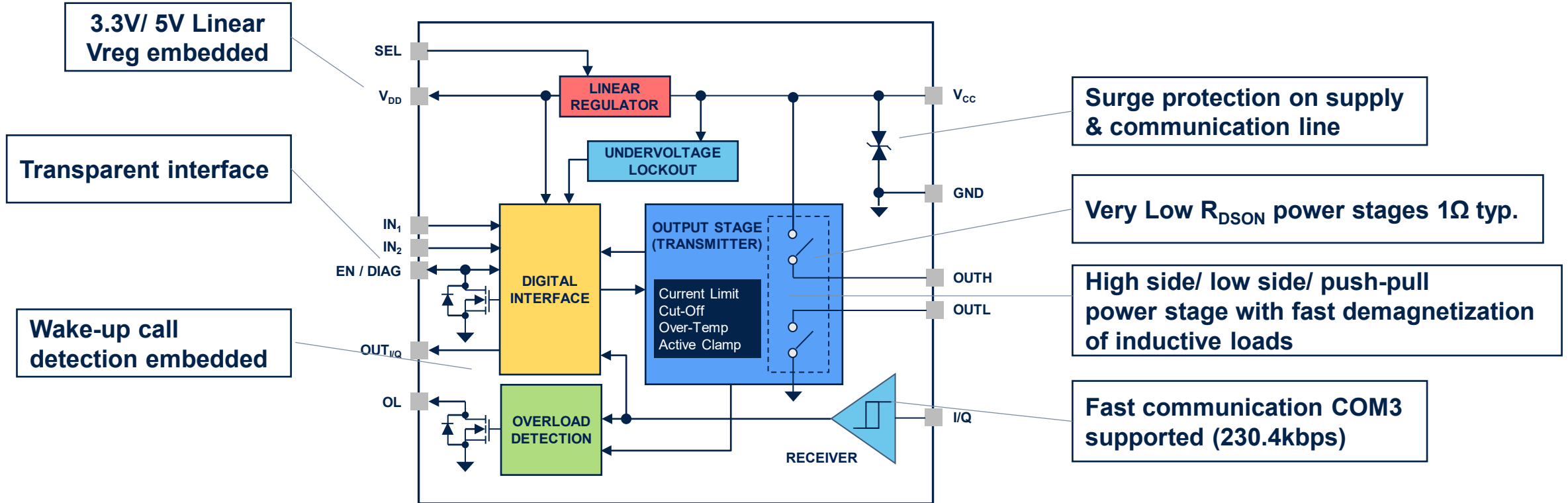

L6362A



• Key Benefits

• Best in class for power losses

- Low $R_{\text{DS(on)}}$ $1\ \Omega + 0.8\ \Omega @ 25^\circ\text{C}$

Low Power Dissipation
Reduced power losses

• Optimized for simple solutions

Cheap Interface

• Fast switching (up to COM3)

High Frequency
Operation

• Selectable Output Stage:

- High Side
- Low Side
- Push/Pull

High flexibility
Customer customization

• Fully protected

- Reverse Polarity
- Over-current / short-circuit
- Thermal protection
- Non dissipative short circuit (cut-OFF delay time)
- Under-voltage

High reliability



Key specs for L6362A

Maximum supply voltage of L6362A	36V
IOHS max Spec for L6362A	310mA
IOHS-PEAK max Spec for L6362A	450mA
Output Voltage of integrated LDO	3.3V or 5V
L6362A internal LDO output Current Capability	10mA
L6362A internal LDO Output Short-circuit limitation	20mA
Typical Rds(ON) for L6362A High-Side Switch (Iout=0.1A, Tj=25°C)	1Ω
Typical Rds(ON) for L6362A Low-Side Switch (Iout=0.1A, Tj=25°C)	0.8Ω

IO-Link sensor

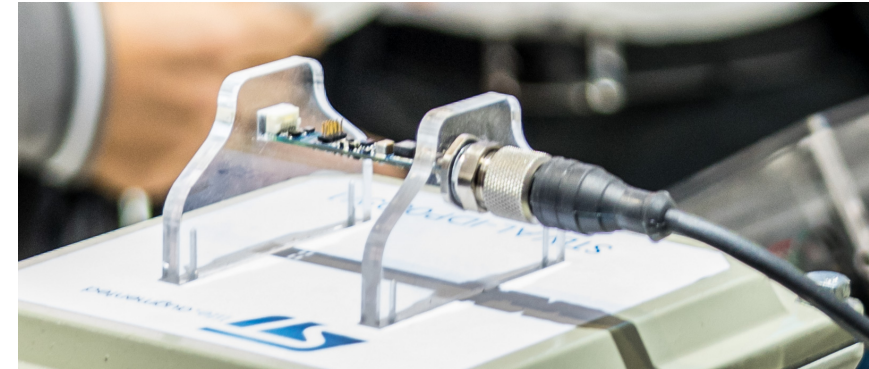
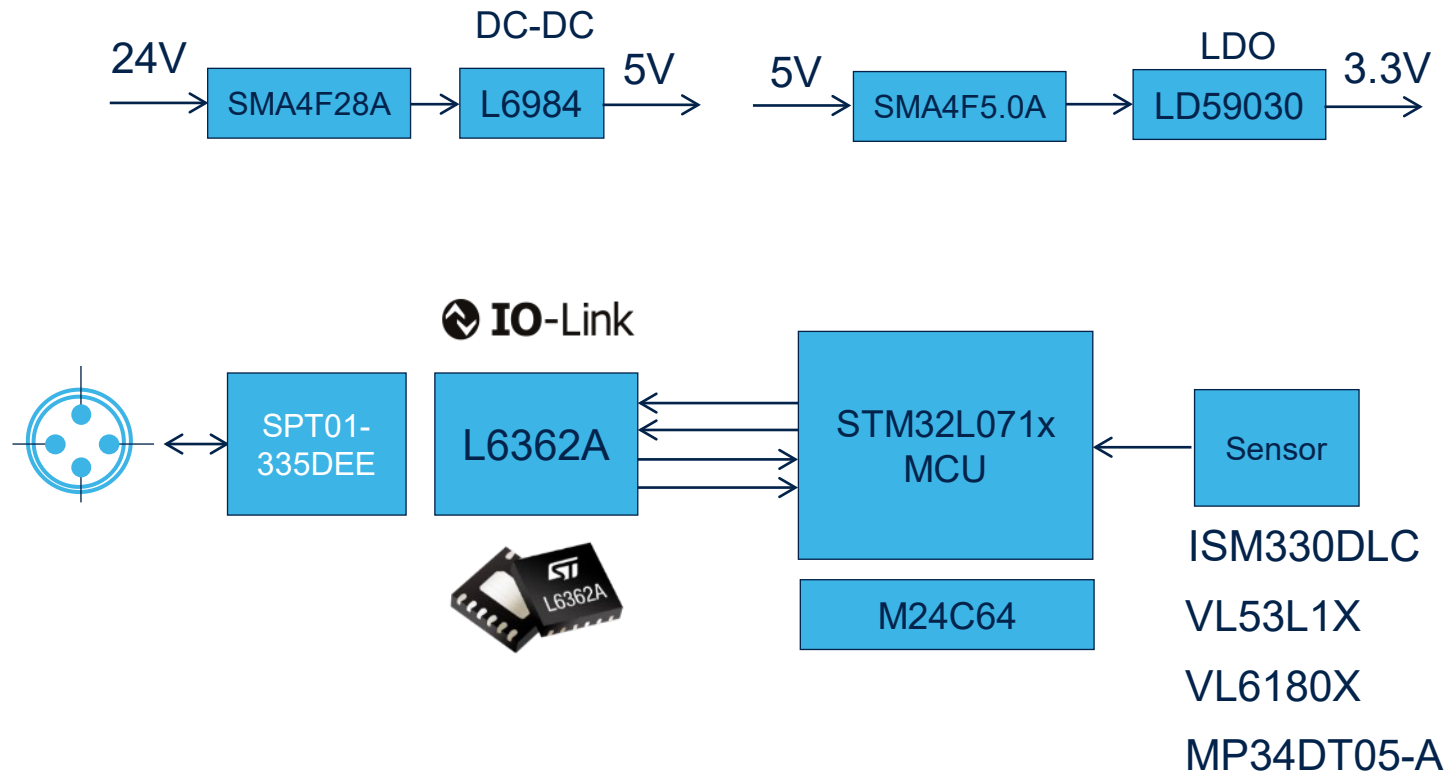

- Position
- Pressure
- Flow
- Level
- Temperature
- Proximity
- Inclination
- Encoder, Linear Position
- Cabinet Condition Monitoring
- Ultrasonic/Photoelectric
- Inductive Couplers...

IO-Link actuator

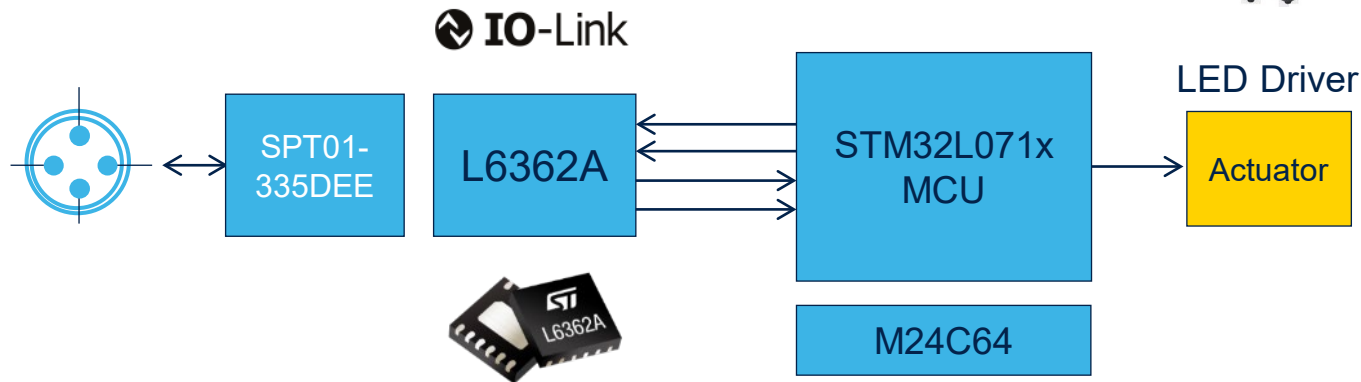

- RGB LED Indication
- Relay Drive
- Motor Drive
- Switch ON/OFF
- Pressure Relief Valve
- Solenoid Valve

IO-Link to DI/DO

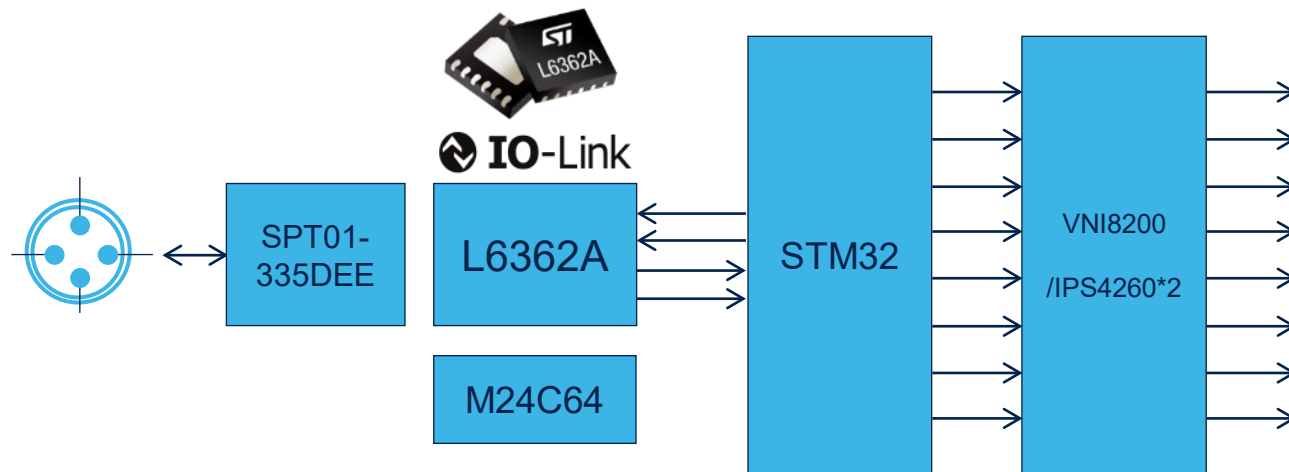
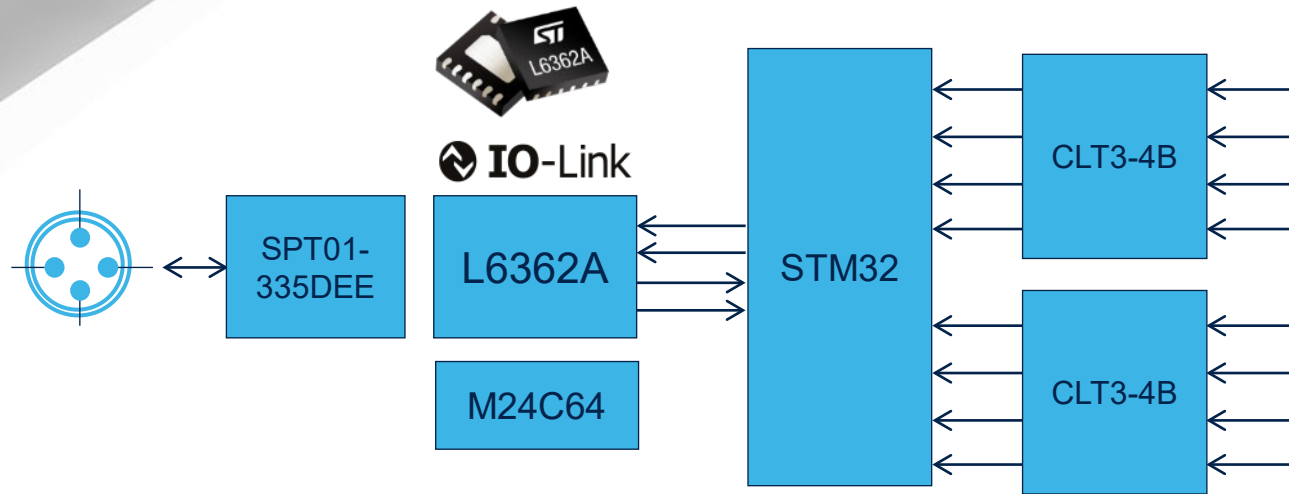
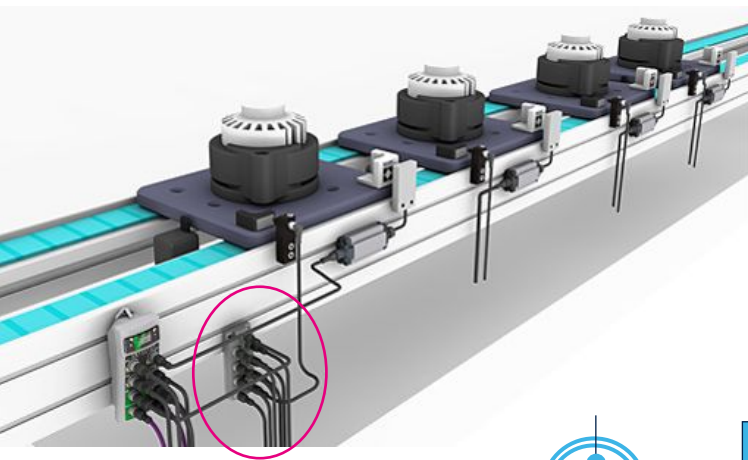

IO-Link Master PHY

IO-Link master PHY

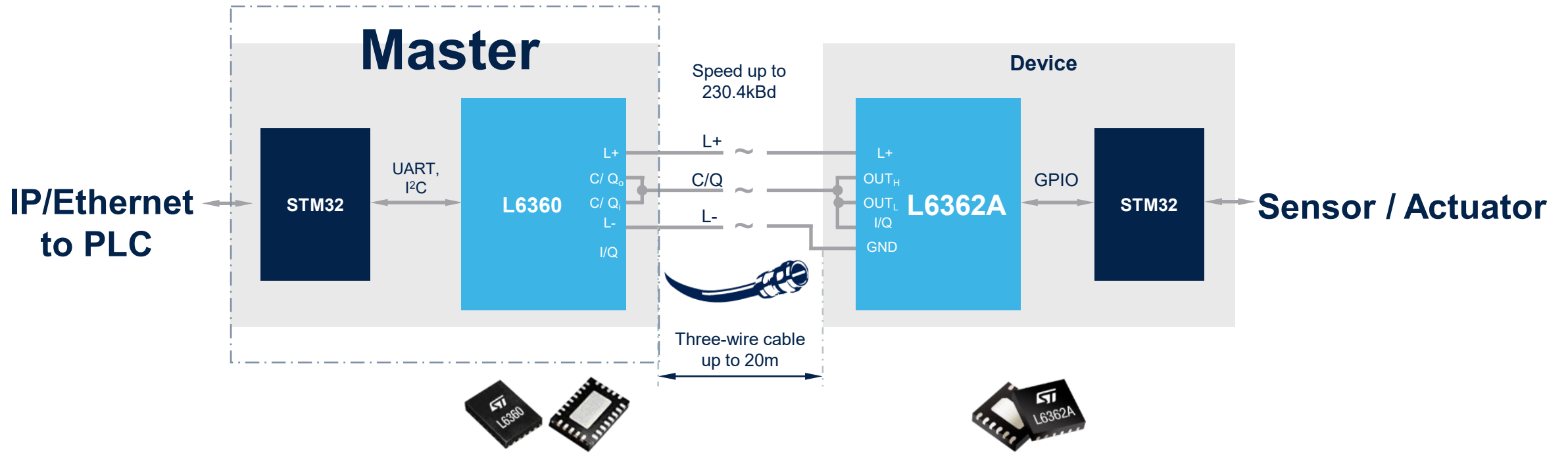

- Easy Installation
- Easy Configuration
- Diagnostic Function

L6360 master PHY

Direct access to line drivers / receivers for transparent operation

Digital interface to 9 internal register for chip programmability & diagnostics

LED Drivers + sequence generators embedded

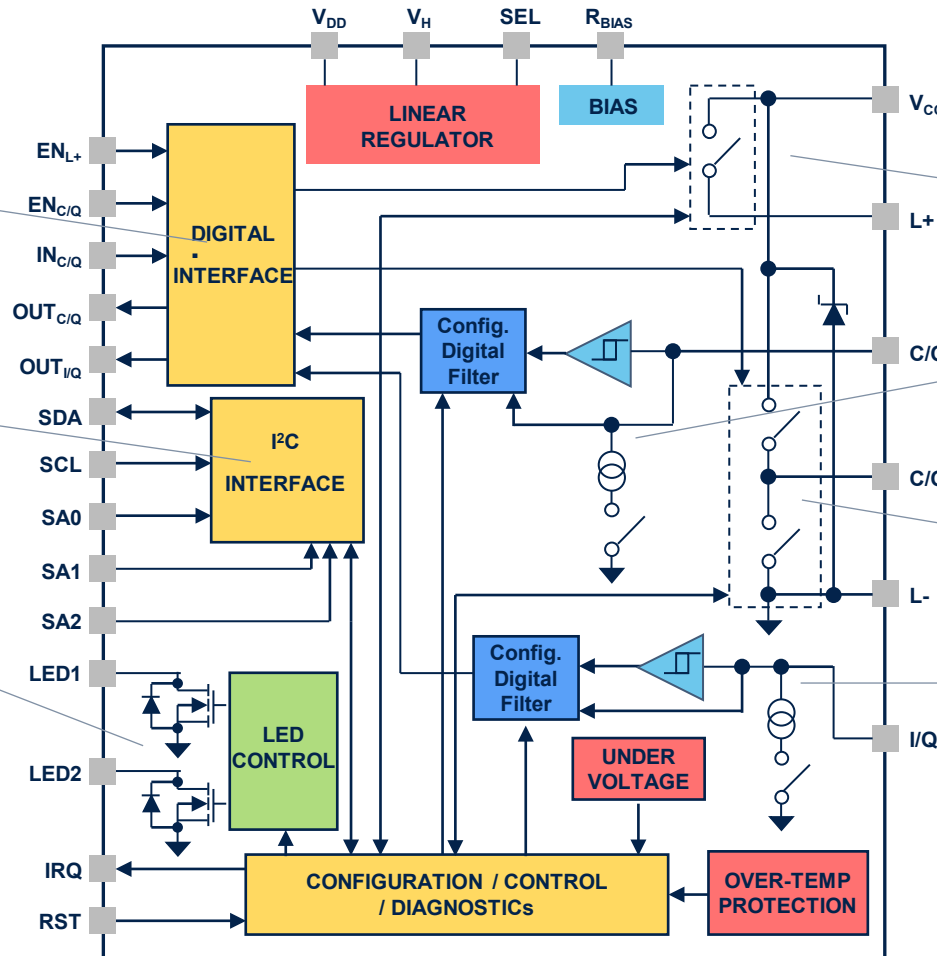

Configurable power switch with very low $R_{DS(ON)}$: 2 Ω max.

Receiver with digital filter and very precise configurable current sink

Configurable line driver with very low $R_{DS(ON)}$: 2 Ω max. (HS); 1.2 Ω max. (LS)

Additional digital input with digital filter & current sink

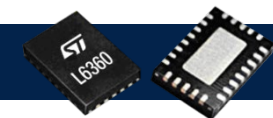

Key specs for L6360

Maximum supply voltage of L6360	32.5V
Output Voltage of integrated LDO	3.3V or 5V
L6360 internal LDO output current capability	50mA
L6360 internal LDO output current limitation	65mA
Max spec of C/QO Low-side & High-side limitation current	1600mA
Typical Rds(ON) for L6360 C/QO High-side Switch (Iout=0.2A, Tj=25°C)	1Ω
Typical Rds(ON) for L6360 C/QO Low-side Switch (Iout=0.2A, Tj=25°C)	0.6Ω
Max I2C clock frequency for L6360	400KHz

IO-Link master

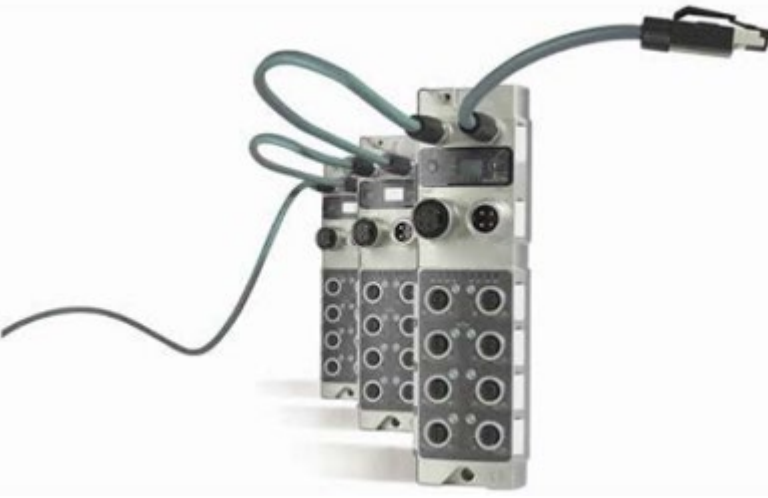

EtherNet/IP™

OR

PROFI
NET®

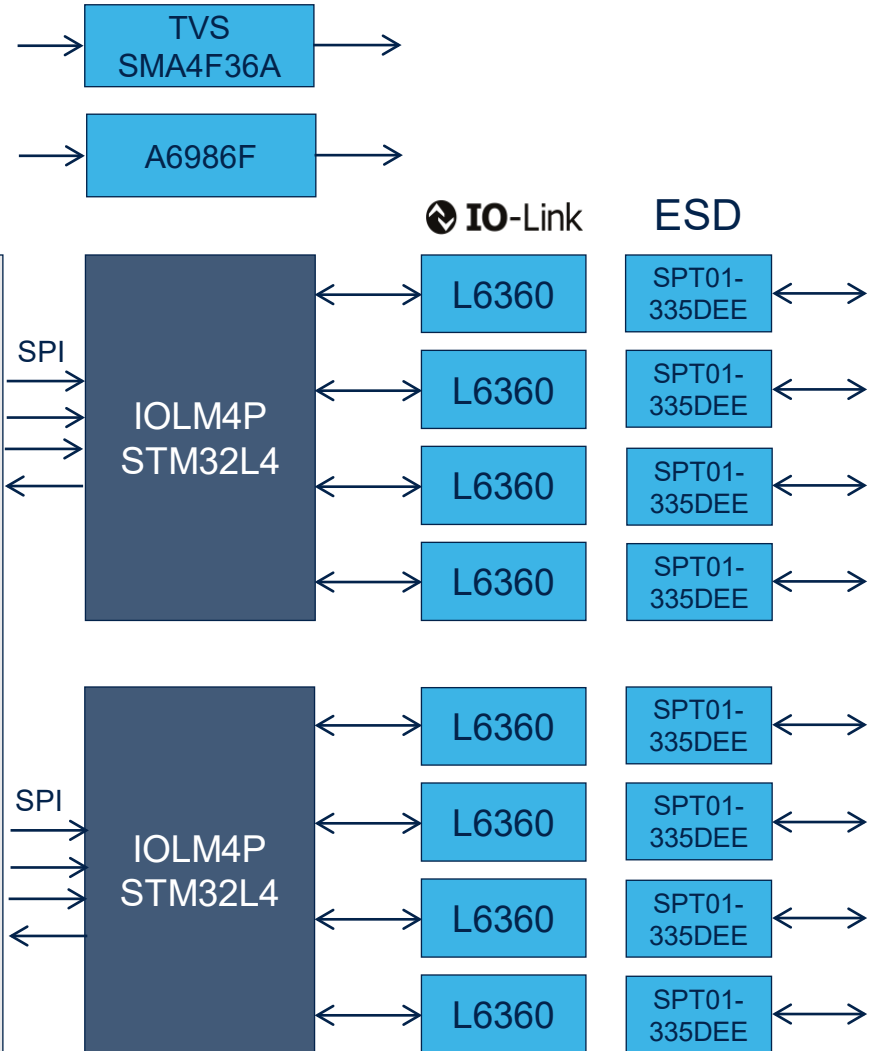
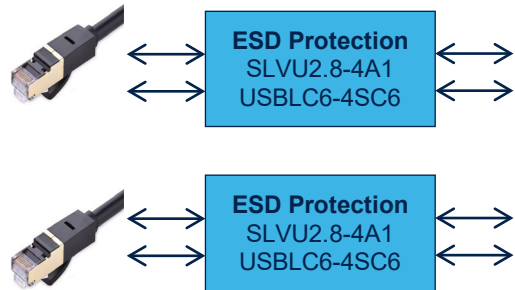

IO-Link evaluation boards

L6360 & L6362A evaluation boards

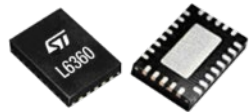

L6360: QFN 26L 3.5 x 5

L6362A: DFN 12L 3 x 3



L6360 Master	1 × L+, 1 × C/Q, 1 × DI	0.5	UM2421	kit P-NUCLEO-IOM01M1	Stack included
	1 × L+, 1 × C/Q, 1 × DI		DB3632 , UM2430	STEVAL-IOM001V1	
	1 × L+, 1 × C/Q, 1 × DI		AN4075	STEVAL-IFP016V2	New! IO-Link Stack coming soon
	4 × L+, 4 × C/Q, 4 × DI		AN5041 , UM2232	STEVAL-IDP004V1	
L6362A Device	1 × C/Q (HS+LS+DI)	0.3	UM2425	kit P-NUCLEO-IOD01A1	Stack included
			DB3634 , UM2424	STEVAL-IOD003V1	
			AN4828	STEVAL-IFP017V3	New! IO-Link Stack coming soon
			AN5041 , UM2232	STEVAL-IDP003V1	
			DB3663 , UM2438	STEVAL-BFA001V1B	



[P-NUCLEO-IOM01M1](#) kit



[STEVAL-IFP016V2](#)

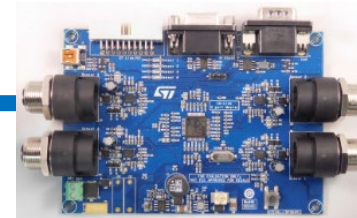

[STEVAL-IDP004V1](#)

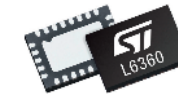

[P-NUCLEO-IOD01A1](#) kit



[STEVAL-IFP017V3](#)



[STEVAL-IDP003V1](#)

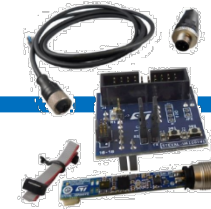

[STEVAL-BFA001V1B](#)



L6362A Demo is Coming



life.augmented

Please Scan the QR Codes
and Stay Tune with Us.



PDSA Wechat Subscription



Power & SPIN Microsite



Thank you

© STMicroelectronics - All rights reserved.

ST logo is a trademark or a registered trademark of STMicroelectronics International NV or its affiliates in the EU and/or other countries.

For additional information about ST trademarks, please refer to www.st.com/trademarks.

All other product or service names are the property of their respective owners.



life.augmented